

# Manometerkraner Fig. 10 og 14

Fig. 10, messing

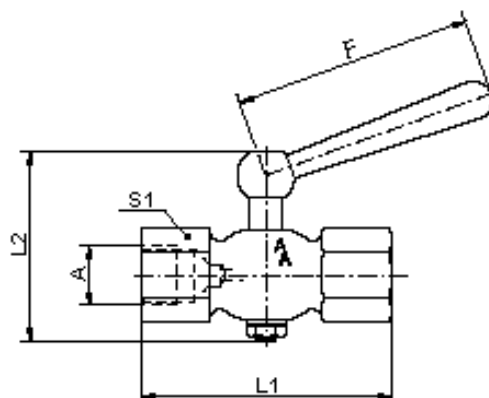
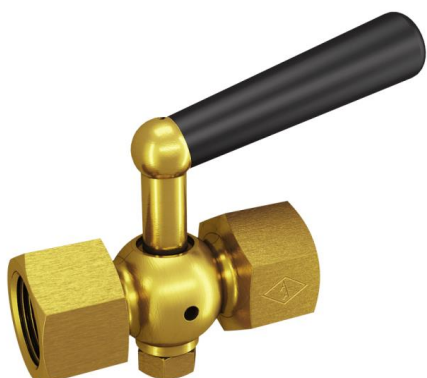

A	PN / bar	°C	L1 / mm	L2 / mm	F / mm	S1 / mm	Art. nr.	Nrf. nr.	
1/4"	6	50	48	39	28	17	63001L	9706812	
3/8"	6	50	46	39	28	22	9091807	9706814	
1/2"	6	50	60	43	62	24	9X00044	9706816	

Fig. 14, messing

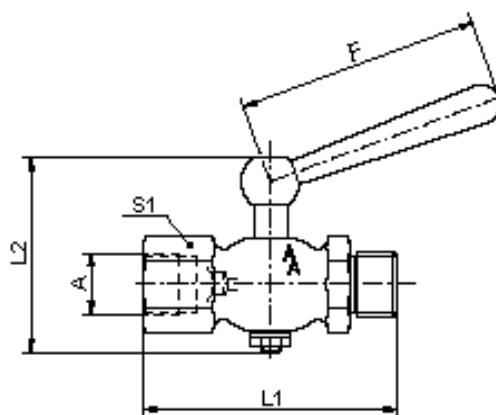

A	PN / bar	°C	L1 / mm	L2 / mm	F / mm	S1 / mm	Art. nr.	Nrf. nr.	
1/4"	6	50	43	39	28	17	9090070	9706813	
3/8"	6	50	46	43	28	22	9091815	9706815	
1/2"	6	50	60	43	62	24	9X90095	9706817	

Det anbefales å benytte egnet bunntetning (pakning) mellom manometer og kran.

